

<https://doi.org/10.22306/asim.v11i1.118>

Received: 04 Feb. 2025

Final revised: 24 Feb. 2025

Accepted: 19 Mar. 2025

## **A case study of using Solidworks software to simulate an assembly for 3D printing and creating a digital twin of Wlkata robots in laboratory conditions**

### **Jan Kopec**

Komenského park 9, 040 01 Košice, Technical University of Košice, Faculty of Mechanical Engineering, Letná 1/9, 042 00 Košice, jan.kopec@tuke.sk (corresponding author)

### **Miriam Pekarcikova**

Komenského park 9, 040 01 Košice, Technical University of Košice, Faculty of Mechanical Engineering, Letná 1/9, 042 00 Košice, miriam.pekarcikova@tuke.sk

### **Juraj Kovac**

Komenského park 9, 040 01 Košice, Technical University of Košice, Faculty of Mechanical Engineering, Letná 1/9, 042 00 Košice, juraj.kovac@tuke.sk

### **Erik Varju**

Komenského park 9, 040 01 Košice, Technical University of Košice, Faculty of Mechanical Engineering, Letná 1/9, 042 00 Košice, erik.varju@tuke.sk

### **Marek Mizerak**

Komenského park 9, 040 01 Košice, Technical University of Košice, Faculty of Mechanical Engineering, Letná 1/9, 042 00 Košice, marek.mizerak@tuke.sk

**Keywords:** 3D printing, SolidWorks, RoboDK, Prusa, simulation.

**Abstract:** This article deals with the use of SolidWorks software to simulate the assembly of an assembly intended for 3D printing, as well as the creation of a digital twin of the WLKATA robots under laboratory conditions. The simulation allowed for efficient testing of the conveyor belt design before production, minimizing design errors and reducing material consumption. The SolidWorks simulation results were then validated by 3D printing using a Prusa XL printer and tested in integration with WLKATA's educational robots. Part of the process included optimization of the parts for the manufacturing tolerances of FDM printing, with major flaws identified and corrected before actual printing. In addition to simulation and printing, a digital simulation of the assembly in RoboDK software was also carried out to verify the compatibility of the mechanisms. The results showed that the combination of simulation in SolidWorks and RoboDK provides an efficient approach to the design and testing of mechanical assemblies while minimising manufacturing costs and environmental footprint.

## **1 Introduction**

Design verification should be an obvious part of the product development process. With its help, the designer should continuously make sure that his design will be reliable and safe and will not suffer from excess material. And possibly meet other complex functional requirements, such as verification of dynamic properties of mechanisms, frequency and temperature analysis, or gas and fluid flow analysis [1].

The tools for all these inspections and analyses are nowadays readily available, intuitive and easy to master for any user thanks to SOLIDWORKS Simulation. The integration of simulation tools into SOLIDWORKS is of course essential. By working on the same model, the integration ensures not only uniform and consistent control, but also the necessary associativity between the design and its verification. Thus, the user can safely change the dimensions of the model, while the set fit and model load are automatically adapted to the modified geometry, thus ensuring the correctness of the new simulation. In

addition to performance and speed, support for a wide portfolio of simulations and solving problems is another prerequisite for success [2,3].

Advantages of SolidWorks simulation:

- Simple and easy-to-use, intuitive environment.
- Powerful enough for experienced computational engineers, yet simple enough for design engineers.
- The ability to test product designs and eliminate errors and imperfections early in the design process, well before the prototype or production piece is produced.
- The fastest computational algorithm offers unmatched performance and runs in the background so that concurrent simulation does not disrupt your workflow in any way.
- With fast problem-solving, it's no problem to try different scenarios and gradually change the task until you get to the most accurate solution you need.

## A case study of using Solidworks software to simulate an assembly for 3D printing and creating a digital twin of Wlkata robots in laboratory conditions

Jan Kopec, Miriam Pekarcikova, Juraj Kovac, Erik Varju, Marek Mizerak

- Easily accessible results in the form of automated reports or interactive eDrawings.

The WLKATA Mirobot is a compact 6-axis robotic arm designed for educational purposes, allowing students and robotics enthusiasts to learn about the principles of industrial automation. Inspired by the ABB IRB 6700 industrial robot, Mirobot offers a repeatable positioning accuracy of 0.2 mm. It comes in a complete kit, ready for immediate use out of the box [4,5].

Advantages:

- Intuitive programming: the user interface allows drag-and-drop programming, making it suitable for students of all ages.
- The kit includes a pneumatic kit, power supply, high-speed USB and IDC cables, a multi-function box for extensions and other accessories.
- Various control methods: Supports control via smartphones, and apps and is expandable with external interfaces such as Bluetooth, Wi-Fi and RS485.

FDM (Fused Deposition Modeling) is one of the most widely used 3D printing methods that uses thermoplastic materials to create three-dimensional objects layer by layer. The process works by having a print head extruding molten filament (usually PLA, ABS, PETG, or other polymers) through a nozzle onto a print substrate, with the material gradually solidifying to form the desired shape (Figure 1).

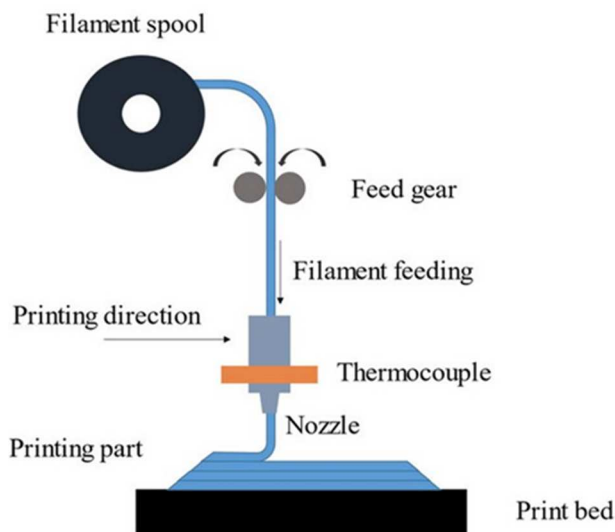

Figure 1 The principle of 3D printing

The advantage of FDM printing is its affordability and the wide range of materials that offer different properties. In addition, FDM printers are suitable for both domestic and industrial use, enabling the production of prototypes, functional parts, and design models.

## 2 Simulation of the solution under laboratory conditions

For the case study, we developed a conveyor belt model. SolidWorks was used to create the model because of its accessibility in our department. The individual parts were created in Part. This is because of the simpler process of 3D printing.

The list of individual components is elaborated in Table 1.

Table 1 List of components for the assembly

Name	Quantity
Base rectangular stabilizer	1
Bearing	4
Belt holder	2
Belt link	44
Driven Shaft	1
Free Shaft	1
Header moving side	1
Header standing side	1
Legs	2
Link	44
M8 nut	4
Sprocket inventor	2
Sprocket inventor (large hex)	2
Static roller support	1
Static roller support (Motor side)	1
Tensioner bolt	2
Tensioner roller support	2
Tensioner support plate	2
Torsional arm	1

Once the 3D models have been created, it is possible to start the process of simulating the assembly process in order to detect any inaccuracies. Figure 2 shows the process of joining the different parts of the conveyor belt in order to create a working model that can be printed on a 3D printer.

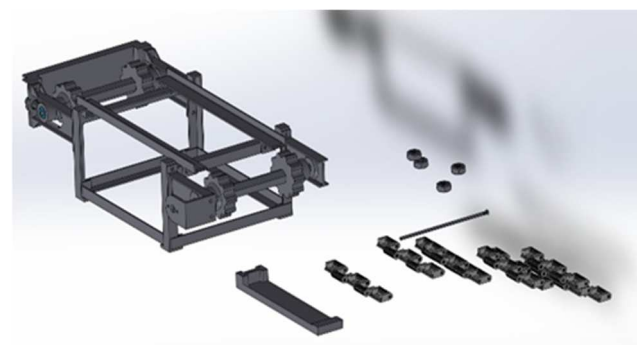

Figure 2 The process of joining components in SolidWorks

**A case study of using Solidworks software to simulate an assembly for 3D printing and creating a digital twin of Wilkata robots in laboratory conditions**

Jan Kopec, Miriam Pekarcikova, Juraj Kovac, Erik Varju, Marek Mizerak

When joining the Assembly section, some parts were found to have significant inaccuracies that could ultimately render the entire conveyor belt inoperable. Specifically, these were the link and belt holder models. In the case of the link part, the diameter had to be adjusted. In the case of 3D printing, a certain deviation of 0.02-0.03 mm is also considered, depending on the printer settings. Therefore, the diameter had to be reduced by the deviation, which in our case was 0.03mm.

Figure 3 shows the whole conveyor belt connected in the assembly section.



Figure 3 Conveyor assembly simulation

By simulating the assembly of the conveyor belt, any possible accuracy variations were eliminated, thus saving money, filament, and environmental burden.

The SolidWorks simulation verified the accuracy and capabilities of the assembly, and if everything met the requirements it was possible to use the 3D printing process to create a working model for laboratory purposes.

At the beginning of the preparation of the model for 3D printing, the individual parts need to be saved in .stl format. This kind of format contains information about the geometry of the 3D object in the form of triangular meshes that define its surface properties.

For the printing process, a printer from Prusa was used, namely the Prusa XL (Figure 4).

Printer (Figure 4) has 5 print heads and is one of the fastest multi-tool 3D printers in the world. Prusa recommends using their slicer, PrusaSlicer, for the best print setup and results.

Figure 5 shows the PrusaSlicer environment. Due to the size of the models, the number of models, and the size of the print area, it was necessary to divide the printing into parts. The fill material used was 20% and the material used was PLA.



Figure 4 Prusa XL

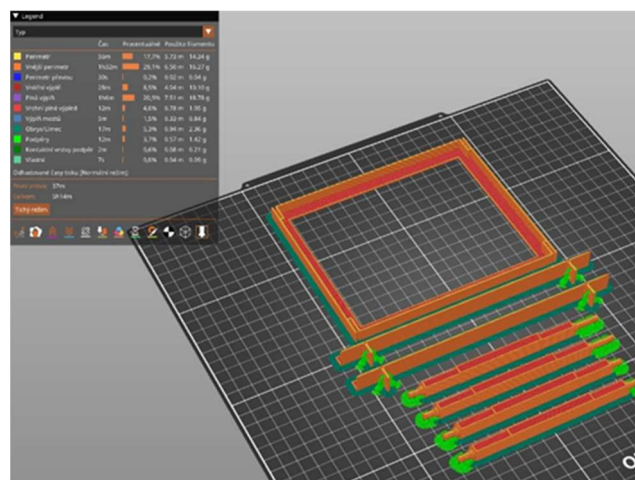

Figure 5 Setting model properties for 3D printing

After the models were printed, it was necessary to visually check the quality and, if necessary, remove any impurities. The simulation in SolidWorks was a tool where we were able to create the assembly procedure according to the exact steps.

After assembly, the next stepper motor to move the belt is tested to see if it has a sufficient speed setting and if a more powerful motor should be considered.

After testing with the Arduino UNO, it was found that the motor has enough power to turn the belt to the first. The

## A case study of using Solidworks software to simulate an assembly for 3D printing and creating a digital twin of Wlkata robots in laboratory conditions

Jan Kopec, Miriam Pekarcikova, Juraj Kovac, Erik Varju, Marek Mizerak

model assembled and ready for interfacing with the WLKATA educational robots is shown in Figure 6.



Figure 6 Integration of models under laboratory conditions

RoboDK software was used as a simulation tool for the whole process of linking the WLKATA robot and the conveyor belt model.

RoboDK is a powerful simulation and offline programming software for industrial robots. It allows users to program robot arms without the need for direct hardware intervention, reducing the risk of errors and reducing the time required for testing. RoboDK offers several benefits such as support for a range of robotic devices, offline programming and import of CAD models.

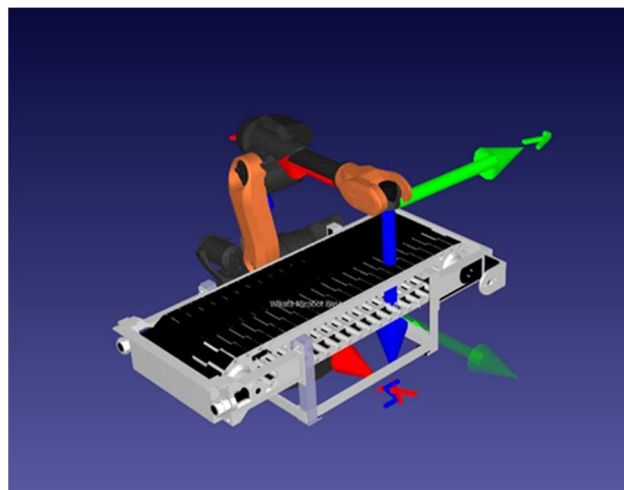

Figure 7 Digital model in RoboDK

### 3 Results and discussion

The main objective of the study was to verify the accuracy and feasibility of the conveyor belt design prior to its physical manufacture using a combination of simulation in SolidWorks and a digital twin created in RoboDK. The results showed that the use of simulation tools contributed significantly to the optimization of the design and the elimination of possible inaccuracies before the actual 3D printing [6,7].

During the SolidWorks simulation, minor inaccuracies in the geometry of some components were identified, especially in the link and belt holder fasteners. The original design showed a deviation of 0.03 mm, which could lead to an incorrect fit and subsequent non-functionality of the assembly. Thanks to simulation, it was possible to correct these errors before production, thus avoiding unnecessary waste of filament and reducing the environmental burden.

After 3D printing and assembling the model, the conveyor belt drive was tested using a stepper motor and an Arduino UNO control board. Testing showed that the motor had sufficient power to move the belt at the required speed, confirming the correctness of the design [8,9].

A simulation of the conveyor belt interacting with the WLKATA Mirobot educational robots was carried out in the RoboDK software. The simulation confirmed that the robots can manipulate objects on the belt with the required accuracy and that the design is suitable for laboratory teaching applications.

### 4 Conclusions

This study investigated the use of SolidWorks, RoboDK, and 3D printing in the design and testing of mechanical assemblies in laboratory conditions. The main objective was to simulate and optimize a model of a conveyor belt intended for integration with WLKATA Mirobot educational robots, analyzing design accuracy, manufacturability, and functionality under real-world conditions.

## A case study of using Solidworks software to simulate an assembly for 3D printing and creating a digital twin of Wlkata robots in laboratory conditions

Jan Kopec, Miriam Pekarcikova, Juraj Kovac, Erik Varju, Marek Mizerak

Based on the simulation results, it was possible to identify and eliminate design inaccuracies before the actual production, minimizing the risk of errors during 3D printing. Geometry adjustments, especially for fasteners, were shown to be necessary to ensure the correct assembly and functionality of the overall system. Without digital simulation, these issues could lead to inefficient material usage and additional costs for repairs and adjustments to the model.

The use of 3D printing to produce mechanical components has demonstrated its advantages in rapid prototyping and design testing. Thanks to FDM technology, it was possible to efficiently produce individual parts of the model and verify their compatibility in real conditions. It is the combination of simulation and 3D printing that has proven to be an effective approach to validate design concepts before physical implementation.

Another important part of the experiment was to verify the integration of the conveyor belt with the WLKATA robots. Simulations in the RoboDK software confirmed that the robots can manipulate objects on the belt with sufficient precision, setting the stage for future applications in automation and robotics education. This experiment proved that the use of digital twins and simulation tools contributes significantly to the efficiency of system development and testing in laboratory conditions.

### Acknowledgement

This article was created by the implementation of the grant projects: APVV-17-0258 Digital engineering elements application in innovation and optimization of production flows, APVV19-0418 Intelligent solutions to enhance business innovation capability in the process of transforming them into smart businesses. KEGA 020TUKE-4/2023 Systematic development of the competence profile of students of industrial and digital engineering in the process of higher education. VEGA 1/0508/22 „Innovative and digital technologies in manufacturing and logistics processes and system“, KEGA 003TUKE-4/2024 Innovation of the profile of industrial engineering graduates in the context of required knowledge and specific capabilities for research and implementation of intelligent systems of the future. VEGA 1/0383/25 Optimizing the activities of manufacturing enterprises and their digitization using advanced virtual means and tools.

### References

- [1] TREBUŇA, P., PEKARČIKOVÁ, M., FILO, M.: *Digital factory*, Lüdenscheid: RAM-Verlag, 2024.
- [2] ATTARAN, M., ATTARAN, S., CELIK, B.G.: The impact of digital twins on the evolution of intelligent manufacturing and Industry 4.0, *Advances in Computational Intelligence*, Vol. 3, No. 11, pp. 1-15, 2023. <https://doi.org/10.1007/s43674-023-00058-y>
- [3] RATHORE, M.M., SHAH, S.A., SHUKLA, D., BENTAFAT, E., BAKIRAS, S.: The Role of AI, Machine Learning, and Big Data in Digital Twin-ning: A Systematic Literature Review, Challenges, and Opportunities, *IEEE Access*, Vol. 9, pp. 32030-32052, 2021. <https://doi.org/10.1109/ACCESS.2021.3060863>
- [4] WLKATA ROBOTICS DOKUMENT, OpenMV, LLC, OpenMV IDE v4.1.5, 2024 [Online], Available: <https://openmv.io/pages/download> [28 Nov 2024], 2024.
- [5] KOVALČÍK, J., STRAKA, M., TROJANOWSKA, J.: Utilize educational robots to design logistic systems, *Applied sciences*, Vol. 14, No. 13, pp. 1-16, 2024. <https://doi.org/10.3390/app14135664>
- [6] GREGOR, M., GRZNAR, P., MOZOL, S., MOZOLOVA, L.: Plackett-Burman design, *Acta Simulatio*, Vol. 10, No. 1, pp. 5-9, 2024. <https://doi.org/10.22306/asim.v10i1.104>
- [7] MALKUS, T., KOZINA, A.: The features of negotiations within reverse logistics cooperation, *Acta Logistica*, Vol. 10, No. 1, pp. 111-119, 2023. <https://doi.org/10.22306/al.v10i1.364>
- [8] TAO, F., ZHANG, M.: Digital twin shop-floor: A new shop-floor paradigm towards smart manufacturing, *IEEE Access*, Vol. 5, pp. 20418-20427, 2017. <https://doi.org/10.1109/ACCESS.2017.2756069>
- [9] SZAJNA, A., SZAJNA, J., STRYJSKI, R., SAŚIADEK, M., WOŹNIAK, W.: *The Application of Augmented Reality Technology in the Production Processes*, Intelligent Systems in Production Engineering and Maintenance, ISPEM 2018, Advances in Intelligent Systems and Computing, Vol 835, Springer, Cham., pp. 316-324, 2019. [https://doi.org/10.1007/978-3-319-97490-3\\_31](https://doi.org/10.1007/978-3-319-97490-3_31)

### Review process

Single-blind peer review process.